

VMX650FX-WLMD
3D METAL ADDITIVE SUBTRACTIVE
CNC HYBRID MACHINE CENTER



VMX650FX-WLMD 5 axis traveling bridge machine center features a table size of Ø650 mm, and a work envelope size applicable for complicated simultaneous contouring required for high accuracy machining applications. Superior +/- 3 microns machine accuracy increases profits and reduces scrap. This machine is designed to support the aerospace, medical, molding, automotive and other advanced industries.

The VMX650FX series is engineered using a Traveling Column Bridge to provide rigidity, accuracy, power, and durability, in production of 3 and 5 axis machined parts. The VMX650FX series also offers the option of adding a **“Pallet Pool”**, improving ease of automation. The full system is controlled by a **FANUC 31i-B5**, features continuous motion, and produces sophisticated 5 axis parts. High Precision 35/45/45mm roller linear guides are used with robust Ø45mm pre-tensioned **C2** class ball screws delivering reliable accuracy on X/Y/Z Axes. A Heidenhain rotary encoder is included on the tilting rotary axis for your most demanding applications. Dual contact Big Plus #40 tool holding with two face clamping enables rigid machining and reduces tool wear. An optional HSK A63 spindle is offered, if desired.

The Hybrid 3D metal Additive-Subtractive VMX650FX prints 3D metal parts offering a choice of 10 metal material categories. The 3D metal printing process is **“Powered by Meltio’s laser head”** and uses wire rather than powder, making it safe to use without special protective clothing in a controlled environment, and eliminating the need for additional expensive machinery. The WLMD 3D Metal printing process eliminates most work holding fixtures, has only one machine “set up”, and allows parts to be finished within hours rather than days.

The **NEW VMX650FX-WLMD** is the first of its kind to provide operator control of 5 Axis CNC, 3D Metal Printing, and Robotic automation, using a single 21.5” touch screen. Matched with our QWERTY keyboard, operators can easily monitor and control operations, increasing part quality, reducing training time, and increasing SAFETY by simplifying machine operation.

**VMX650FX-WLMD
3D METAL ADDITIVE-SUBTRACTIVE
CNC HYBRID MACHINE CENTER**

**Start with wire spool material
No specific stock sizes needed**

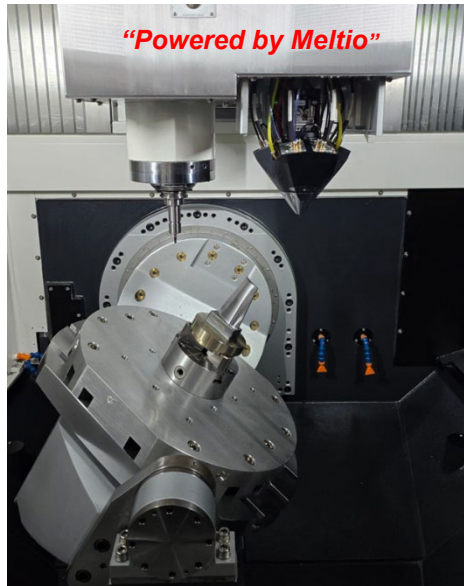

Part being printed



Printed Part



Machined Part

Benefits to a Shop using 3D WLMD (Wire Laser Metal Deposition)

- The WLMD process eliminates the safety hazard of powder deposition methods
- Reduces material costs as parts are printed to a “near net finish” (*within .040”*) eliminating removal of excess material, and reducing “*Cycle Time*”, labor, and power consumption costs.
- Eliminates costs of “Work Holding” fixtures & reduces “Set Up” time.
- **A part can be made using two different metals**, i.e. mild steel as a core metal while the outside is finished with titanium using the “*Twin Wire*” function.
- WLMD parts have fewer voids than forgings or castings – with **99.9998%** density
- Enables parts to be made with internal passageways for gas or liquid flow.
- Allows prototype parts to be made in hours rather than days or weeks.
- The WLMD process eliminates the safety hazard of powder deposition methods.
- No billet needed; all parts can be printed from wire material.

Sample printed parts:



**VMX650FX-WLMD
3D METAL ADDITIVE SUBTRACTIVE
CNC HYBRID MACHINE CENTER**

VMX650FX SERIES STANDARD FEATURES:

- ❖ **Fanuc 31i-B5 with a 21.5" Color Touch Screen**
 - Dynamic Collision Monitoring Software
 - Tool Center Point (TCP) & (TCPM)
 - Smart rigid Tapping
- ❖ **Rotary Table Diameter Ø650x520 mm (Ø25.59" x 20.47")**
 - Max Work Size Ø650 mm (21.17") Height 460 mm (18.11")
 - Max Table Load 300kg/ 300kg (661.39 lbs./ 661.39 lbs.)
 - X/ Y/ Z Axis Travel,700/ 560/ 475mm (27.56"/ 22.05"/ 18.70")
 - Tilt Axis (B Axis), Swiveling Range -90~ +120°; with *Heidenhain ECN Rotary Encoder*
 - Rotary Axis (C Axis) 360°; with *Heidenhain ECN Rotary Encoder*
- ❖ **Max Spindle Power 33 kW (44.25 hp), 166Nm (122,43 ft-lb), S6-15%**
 - Max Spindle Speed 15,000rpm, DDS, Dual Contact CAT #40
 - Fanuc *ai* Spindle Motor, Fanuc *ai* Amplifiers and Servo Motors with Absolute Positioning Encoders,
 - Air Purge/Air Sealed for Spindle Protection
 - Tool Air Blast and Coolant Flush Beside Spindle
 - Spindle Oil Chiller
 - Spindle Air Purge
- ❖ **C2 Class Accuracy Ballscrew and Precision Roller PACK Linear Guides**
- ❖ **X/ Y/ Z Axis Rapid 36/ 36 / 36 m/min (1417/ 1417/ 1417 ipm)**
- ❖ **Side Mount Swing Arm Type ATC – DC CAT 40 & HSK 63 tool pots, 48 Tool Pockets Standard, with 60, & 120 available**
 - Max Tool Dia. Ø75/125mm, Tool Length 250mm, Tool Weight 8 kg
 - Grease Lubrication
 - Automatic Centralized Lubrication System
 - Spindle Oil Chiller
- Full Cabinet Enclosure with Multi Layers Safety Vision Panels EN12417
- Coolant Tank 500L (132 Gallons)
- Coolant Pumps, Two Pumps, Spindle Ring Flushing Pump and Side Flushing Pump
- Heat Exchanger
- Portable MPG, Air Gun and Washing Gun, LED Work Light, Three Status Indicator Light
- MELTIO ENGINE PRINTING SYSTEM - see WLMD feature below.



**VMX650FX-WLMD
3D METAL ADDITIVE SUBTRACTIVE
CNC HYBRID MACHINE CENTER**

MELTIO WLMD 3D ENGINE STANDARD FEATURES:

- The 3D metal printer system prints highly complex components of all shapes and sizes, Integral closed passageway geometries can be printed using different metals in the same part.
- Laser prototypes can be made without complex fixtures
- The Meltio CNC Engine is supplied with Control system with 25" color touch screen.
- Laser Chiller
- Wire drive system keeps wire moving during the print cycles.
- Print Head has six focused lasers to provide safe and accurate laser power to focused to create a "Melt" pool during the printing process.
- Integrate with any 3 or 5 axis CNC machine, converting it into a hybrid metal manufacturing system.
- Makes any 3D metal shape part without inherent constraints and the part size is only limited by the size of the machine work envelope.
- The print head is deployed or retracted automatically by CNC program M Code.
- Printhead Size (WxDxH): 202 x 297 x 784 mm; Printhead Weight 15.5 kg

WLMD GENERAL SPECS

Dimensions (WxDxH):	390 x 700 x 1025 mm	Power Consumption:	2 - 5 kW peak depending on selected options
Print Envelope (WxDxH):	Ø450 x 460mm	Process Control:	Closed-loop, laser and wire modulation
System Weight:	142 kg	Enclosure:	Laser-safe, sealed, controlled atmosphere
Laser Type:	6 x 200 W direct diode lasers	Cooling:	Active water-cooled chiller included
Laser Wavelength:	976 nm	Wire Feedstock Diameter:	0.8 - 1.2 mm
Total Laser Power:	1200 W	Wire Feedstock Spool:	BS300 or Wire drums
Power Input:	208/230V single phase or 400 V three phase		
Wire Materials:	Stainless Steels:	Excellent strength and corrosion resistance.	
	Mild Steels:	Affordable and ductile, with unparalleled machinability and weldability.	
	Carbon Steels:	High impact strength, retain hardness at high temperatures.	
	Titanium Alloys:	Highest strength to weight ratio and corrosion resistance.	
	Nickel Alloys:	High versatility, outstanding heat and corrosion resistance.	

VMX650FX SERIES
DUAL CONTACT SPINDLE
More Rigidity, Lower Vibration, Better Balancing

Model	VMX650 FX		
Spindle Code	12C	15C	24C
Transmission	Coupling	Coupling	Coupling
Max Speed	12,000rpm	15,000rpm	24,000rpm
Bearing	<<>>	<<>>	<<>>
Lubrication	Grease	Grease	Grease or Air/Oil
Spindle Peak Output	18.5kW, 117Nm	33kW, 191Nm S3-15%	11kW, 17.5Nm S3-15%



HIGH PERFORMANCE SPINDLE:

- The spindle is manufactured with P4 grade high-precision ceramic bearings, featuring extended spacing between them, which reduces thermal migration and provides high axial and radial rigidity.
- The standard spindle speed is 15,000 rpm, using an alpha Fanuc amplifier producing 33 kW with a high torque of 166 Nm, suitable for high-speed machining while producing flawless surface finishes.
- The spindle air curtain is a standard accessory, which effectively prevents coolant and chips from entering the spindle and improves the reliability of the spindle.
- Spindle air purge is standard to protect spindle bearings from coolant and chip contamination.

SPINDLE POWER AND TORQUE OUTPUT

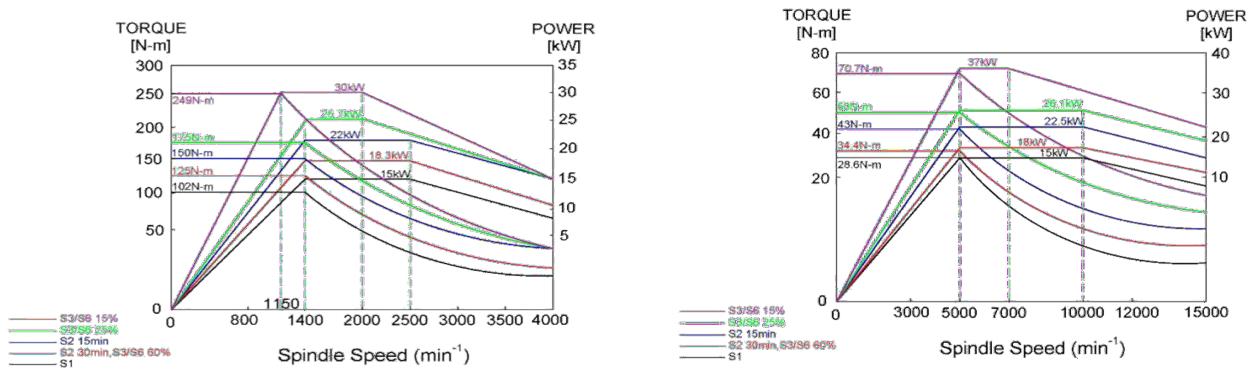

FANUC High Speed Spindle 15,000rpm, Max Power 33kW, Max Torque 166Nm S3-15%

VMX650FX SERIES

CONTINUOUS 5X TABLE WITH DDM TILT AND ROTARY TABLE

- High Precision and efficiency Tilt/Rotary Table.
- Installed with super precision **Heidenhain rotary encoder** (standard feature).
- High speed 60/100 rpm for precision accuracy is provided.
- Kinematic calibration software is included with the VMX650FX series to ensure accuracy.
- Simultaneous five axis operation with five axis TCP (*Tool Center Point*) correction for high precision contouring is included.

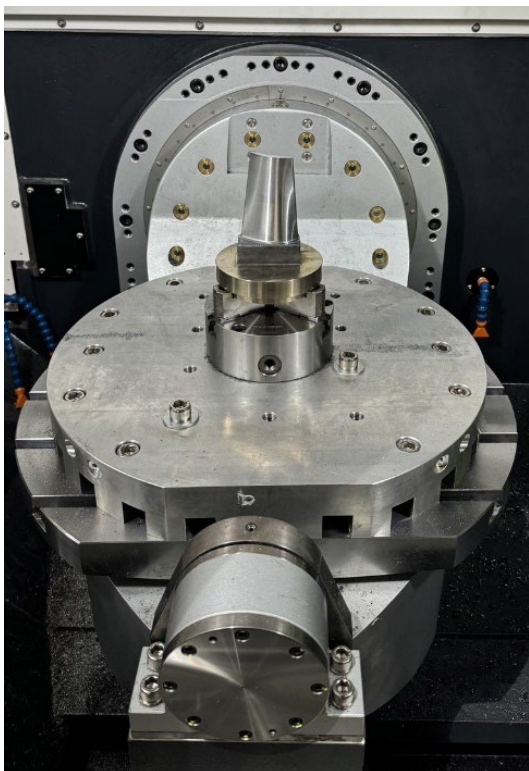

*Printed & machined engine
blade part made of 316SS*



*Machine Part with 3D print
head retracting*

Trunnion rotary table features a Direct Drive “High Torque Motor” for simultaneous machining with precision tolerance. Rotary table diameter of Ø650mm allows large part sizes with auto tool interference detection. Automation can be integrated with a Robotics system through the Robot interface and Rotary Table Rotary Joint Connectors

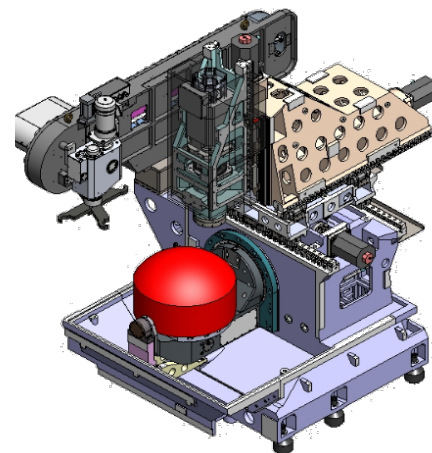

Swiveling range Tilt-Axis Travel: **+90° ~ -120°**
 Max Part Size Diameter x Height: **Ø690mm x 460mm**
 Max Part Weight 0°/90° Detron: **300kg**
 X/ Y/ Z, Axis Travel: 700mm/ 560mm/ 475mm

Jupiter Headquarters, 1124 Enterprise Ave., Galesburg, IL 61401

(309) 342-9342

Jupiter Southeast, 7109-B Greenbrier Rd., Madison, AL 35756

(256) 824-9020

www.JupiterMT.com

Machine Accuracy (mm)

	ISO 10791-2 STANDARD		JUPITER ACCURACY
Straightness full stroke	X	0.02	0.008
	Y	0.015	0.008
	Z	0.015	0.008
Squareness	X-Y	0.02 / 500	0.008 / 500
	Y-Z	0.02 / 500	0.008 / 500
	X-Z	0.02 / 500	0.008 / 500
Positioning Accuracy	X	0.02	0.006
	Y	0.016	0.006
	Z	0.016	0.006
Repeatability	X	0.008	0.004
	Y	0.006	0.004
	Z	0.006	0.004
Spindle run-out on table		0.02 / 300	0.01 / 300
Spindle run-out	At base	0.01	0.004
	At 300mm	0.02	0.008
Circularity	CW	-	0.008
	CCW	-	0.008

VMX650 SERIES SPECIFICATIONS		5F E	5AX P	5AX M
FEED				
Rapid Traverse X/ Y/ Z	m/min	36/ 36/ 36		
Max Acceleration X/Y/Z	G	0.4/ 0.4/ 0.7		
Cutting Feed Rate	mm/min (ipm)	1 -10,000 (0.04 - 394)		
Transmission		Direct		
Axial Motor (X Axis)	kW / HP	4.0 (5.36)		
Axial Motor (Y Axis)	kW / HP	4.0 (5.36)		
Axial Motor (Z Axis)	kW / HP	4.0 (5.36)		
Axial Motor (A Axis)	kW / HP	9.0 (12.07)		
Axial Motor (C Axis)	kW / HP	3.0 (4.02)		
Ball Screw Diameter / Pitch	mm (inch)	45 / 12 (1.77/ 0.47)		
Positioning Accuracy*	mm (inch)	0.01 (0.0004)	0.007 (0.00027)	0.005 (0.0002)
Repeatability Accuracy*	mm (inch)	0.005 (0.0002)	0.005 (0.0002)	0.004 (0.00016)
Guide Ways				
Type (All Axes)		Roller Linear Guide Ways		
Way Size (X axis)	mm (inch)	45 (1.77)		
Way Size (Y axis)	mm (inch)	45 (1.77)		
Way Size (Z axis)	mm (inch)	45 (1.77)		
Blocks on Guide Ways (X/Y/Z)		6 / 4 / 4		
Axial Thrust Force (X Axis)	N	11,519 (2,589.57)		
Axial Thrust Force (Y Axis)	N	11,519 (2,589.57)		
Axial Thrust Force (Z Axis)	N	11,519 (2,589.57)		
Coolant System				
Coolant Tank Capacity	L (gal)	500 (132)		
Nozzle Coolant & Flush Pump	Bar (psi)	3.5 (50.76)		
General				
Machine Size	mm (inch)	W: 3,178 (125.12) x D: 4612 (181.58)		
Height	mm (inch)	3,040 (119.68)		
Weight	kg (lb.)	8,600 (18,960)		
Power Requirements				
Electrical	380V / 60 Hz	3 Phase / 45KVA		
Air		5.5 CFM @ 100 psi		

VMX650FX SERIES

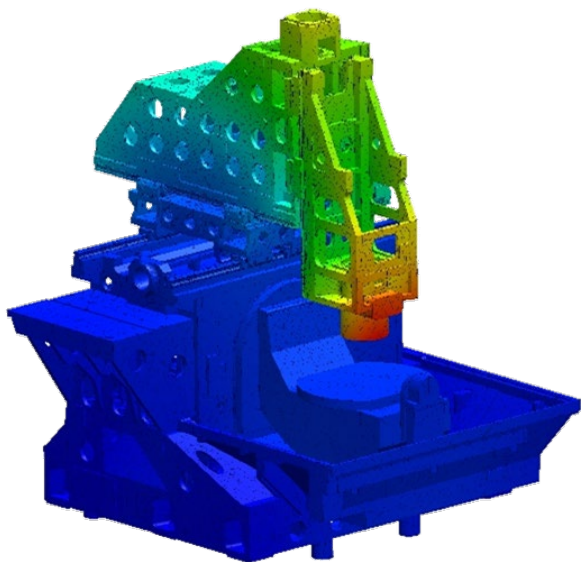

ENGINEERING BY DESIGN AND FEA

Complete Engineering Analysis

FEA techniques are used to analyze structure deformation and stress on the machine, assuring optimal structure composition. FEA analysis results show our machine stiffness is 5.83kgf/um, which is more than 2X the normal stiffness standards of 2.5kgf/um.

One-Piece High Rigidity Structure

Made of a singular joint structure between the base and column with much greater rigidity than other bolt-joined type structures

THERMAL STABILITY PROVIDED BY COOLING STRUCTURE, LINEAR GUIDES & BALL SCREWS

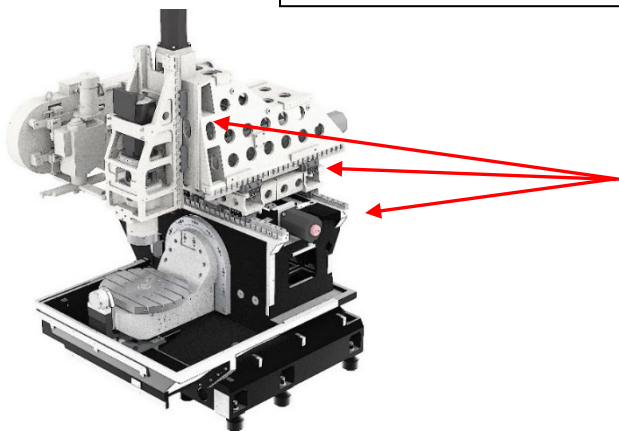

Structure Circulation Cooling of X/Y/Z Linear Guides enhances thermal stability during long run periods.

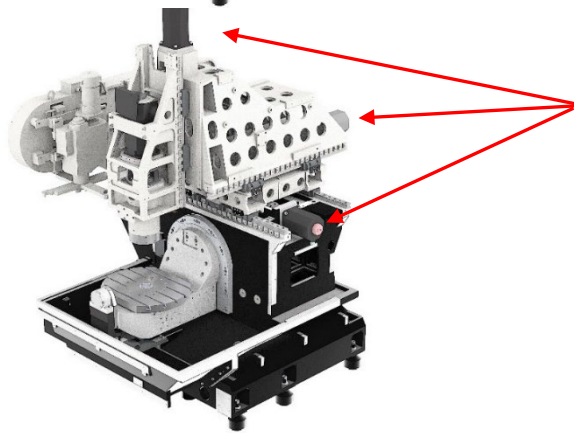

The use of **coolant through ball screws**, provides thermal stability improving accuracy.

EACH JMT MACHINE IS 100% LASER TESTED AND CALIBRATED

Final machine tests and laser calibration are performed on every machine. Geometric accuracy is verified (Straightness, Perpendicularity, Flatness and Squareness). Finally, Circularity is checked by ball-bar test. Test results are stored and provided to customer upon request, at no charge.



Laser calibration is based on full travel.

1. Laser calibration can vary depending on temperature, pressure, humidity, etc.
2. Proper foundation and specified environment conditions are required.

Summarized Laser Calibration Accuracy

Item	X-axis	Y-axis	Z-axis	A-axis	C-axis
Positioning Accuracy	2.081µm	5.008µm	5.354µm	6.53 Arc Sec	3.786 Arc Sec
Repeatability	1.347µm	4.791µm	4.120µm	0.80 Arc Sec	2.304 Arc Sec

VMX650FX SERIES

CONTROL SYSTEM FEATURES

Fanuc 31iB5 Plus Control, 5 Axis Simultaneous Control, High resolution 21.5 Color LCD monitor

- Graphic Display (R094) USB Port
- PCMCIA
- Part Program storage 4M byte / Sub program - 10 folds nested
- Max. 1000 registerable programs expansion / AI Contour Control II (1000 block preview) (r094) / Simultaneously controlled axes expansion Max. 5 axes
- Tool radius•Tool nose radius compensation
- Tool length compensation (G43, 44, 49) / Increment system C 0.0001mm, 0.0001deg, 0.00001inch
- Copy and merge edit functions (expanded edit) / Background Editing
- Multi part program editing / Exact stop Mode (G61-G09) / Circular interpolation
- Helical interpolation / Input/output interface (RS232C)
- Reference point returns (G27-G30) / Rigid tapping
- Feed per minute / feed per revolution (G95) / Absolute/incremental programming (G90, 91) / Inch/metric conversion
- Programmable Data Input G10 / Decimal point programming
- Custom macro-B / pocket calculator type custom macro b
- Tool life management (R094) / Dwell (revolutions or seconds) / Automatic tool offset
- Tool Center Point control (R098)
- Canned cycles for drilling, boring, and tapping (G73, 74, 76, 80-89,)
- Tool offsets addition a (400 tool offsets) (R094) / Mirror image Each axis
- Tool offset memory C (R904) / Backlash compensation
- Interpolation type pitch error compensation / Program protect key
- Self-diagnostic functions
- Keyboard type manual data input (MDI) Skip (G31)

VMX650FX SERIES

CONTROL SYSTEM FEATURES CONTINUED:

- Manual pulse generator
- Run hour and parts count display / Spindle speed override
- Automatic acceleration/deceleration/ Rapid traverse override
- Coordinate system setting (G92) / Feed rate override
- Addition of workpiece coordinate system 48 pairs / Jog override 0 - 655.34%
- Enhanced Embedded Ethernet function / Jog feed
- Run hour and parts count display / Parts counter display
- On-screen spindle load meter display / PCMCIA card attachment
- 32000 STEPS LADDER / DUAL POSITION FEEDBACK
- Machining time stamp
- Built-in 3D interference check
- Tool geometry size data 100-pairs
- 5-axis machining condition setting function / Fast data server
- Dynamic graphic display function / Tool life management
- Manual handle retrace
- Auxiliary function output in the program restart / Quick program restart
- Jerk control
- NURBS interpolation / Smooth tolerance control TWP kit
- 3-dimensional rotary error compensation / High-speed smooth TCP
- 3-dimensional cutter compensation / Work setting error compensation / iHMI basic function
- iHMI set-up guidance / iHMI machining cycle

VMX650FX SERIES
Machine Dimensions

ROTARY TABLE

MUX650 外型尺寸圖
APPROX. WEIGHT :8600 kg

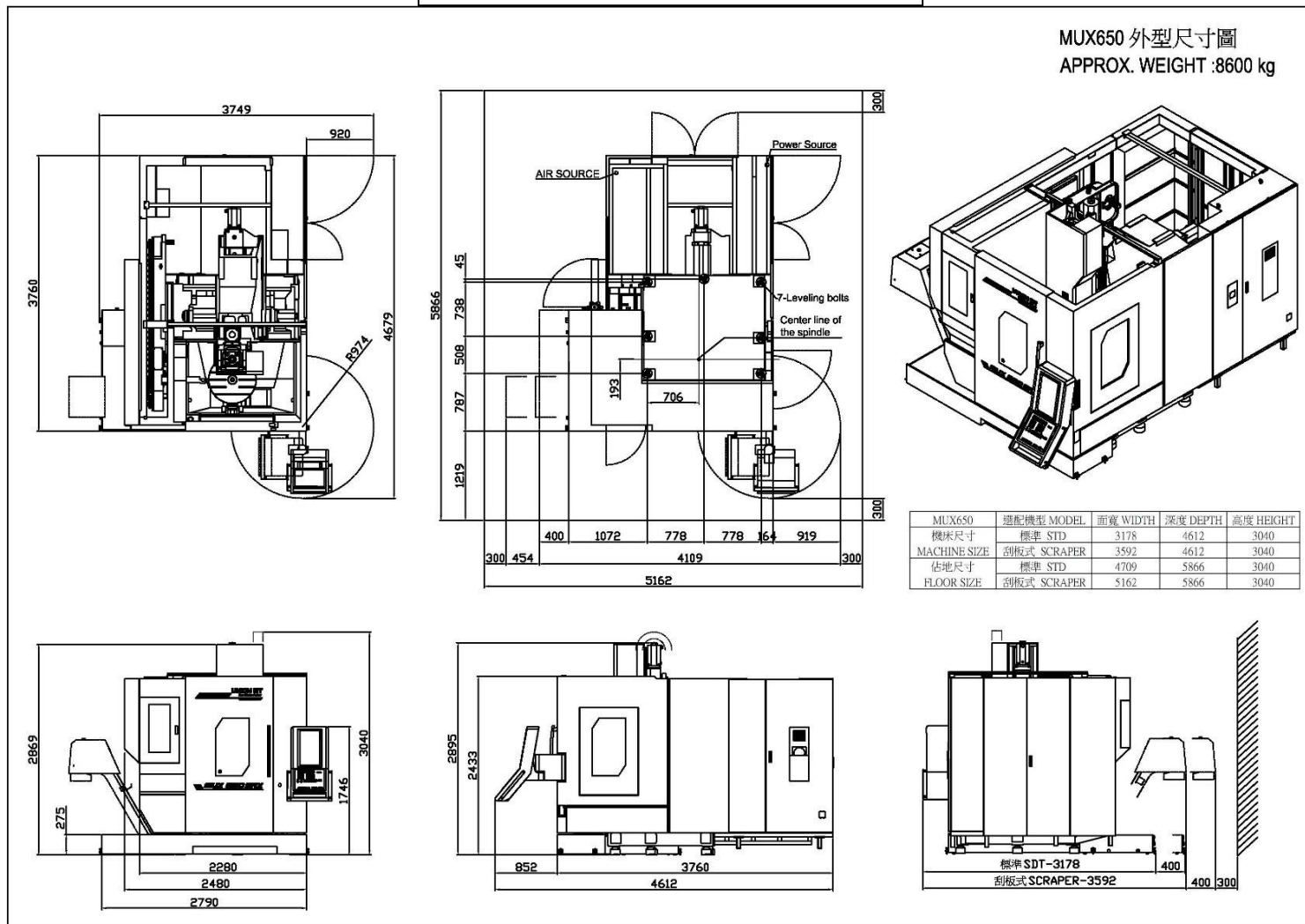
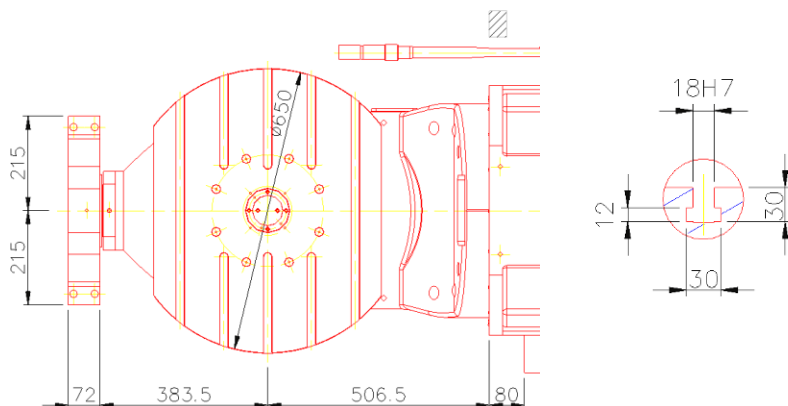

Table Ø650 x 520mm

T Slot 18H7



Jupiter Headquarters, 1124 Enterprise Ave., Galesburg, IL 61401

(309) 342-9342

Jupiter Southeast, 7109-B Greenbrier Rd., Madison, AL 35756

(256) 824-9020

www.JupiterMT.com

Separate Roll Out Coolant Tank

A large (500 Liters) tank with coolant chiller is used to prevent heat transfer from material cutting or chips in the coolant to the machine base casting.

Coolant through Spindle (CTS) and Preparation Kit (Option)

The CTS spindle is optional. Hollow spindle, spindle motor, rotary joint and M codes are assigned. Versatile coolant pressure options including 20 bar, 50 bar, or 70 bar are available. Pumps and filters are not included in the CTS preparation kit.

Lubrication

Automatic centralized greased lubrication is provided to all roller guide ways and ball screws. Grease lubrication is more environmentally friendly than oil lubrication because the very thin grease film can be retained on surface of guide ways and ball screws. Furthermore, grease will not pollute water-based coolant, so there is no need to use an additional oil skimmer, therefore extending the life cycle of coolant.

Remote MPG

Handheld "Manual Pulse Generator" (MPG) lets each axis move in increments of x1, x10 or x100 for easy fixture or part alignment.

Ball Screws and Axis Drives

Each axis is driven by high precision PMI double-nut ball screws or Tsubaki single-nut hollow ball screws. All ball screws are centered between the guide ways. The ball screws are pre-tensioned and supported at both ends with angular contact thrust bearings. All axes are connected directly to Fanuc A.C. digital servo drive motors without the use of gears or belts to eliminate backlash.

Chip Conveyor

Different types of chip conveyors can be chosen based on customer application. Enclosed shield incline angle is designed to ensure chips fall into the conveyor. Multiple chip wash down channels provide coolant flow to wash the chips out of corners in the machine and from the rear chip wash down.